

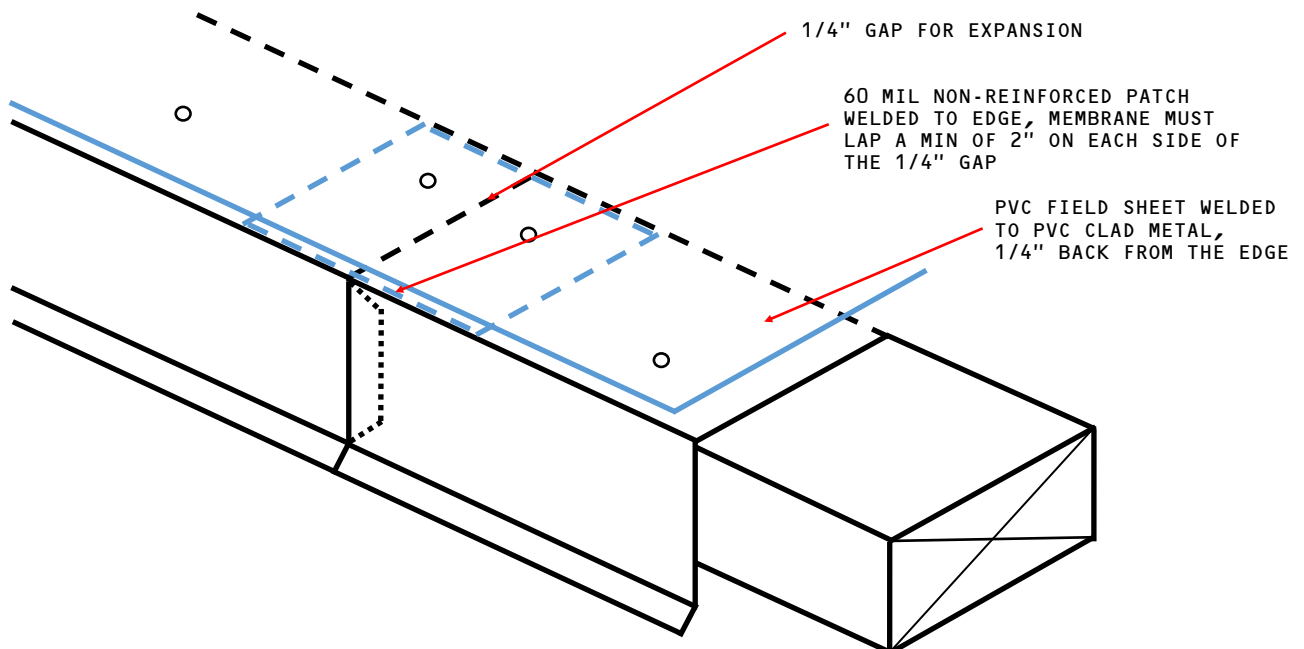

**PHOENIX**  
PRODUCTS™

## Overlap Edge Metal Joint

### Detail PE-GC 11

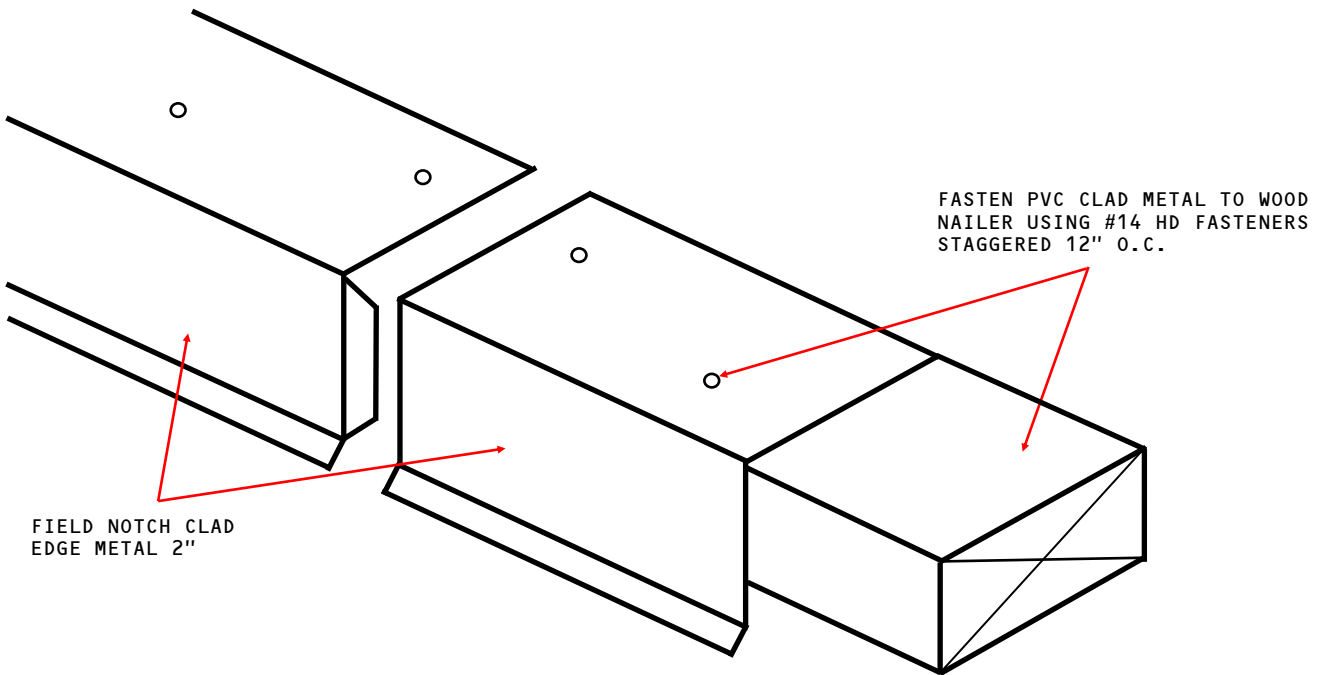

**NOTES:**

1. WOOD NAILER ATTACHED ACCORDING TO LOCAL BUILDING CODE
2. CLEAT REQUIRED ON EDGE METAL WITH FACE GREATER THAN 5"